

## **DOUBLE-TIERED DINING CART**

**CARRITO DE COMEDOR DE DOBLE CAPA**

**CHARIOT À MANGER À DOUBLES ÉTAGES**



### **FOR YOUR SAFETY! | ¡PARA SU SEGURIDAD! | POUR VOTRE SÉCURITÉ!**

Read the instructions before assembling and using the appliance.

Lea las instrucciones antes de montar y utilizar el aparato.

Lisez les instructions avant d'assembler et d'utiliser l'appareil.

### **CONTACT US FIRST! | ¡PÓNGASE EN CONTACTO CON NOSOTROS PRIMERO! | CONTACTEZ-NOUS D'ABORD!**

If you have any questions that are not addressed, please contact us first.

Si tiene alguna pregunta que no se aborde en este Manual del Usuario, póngase en contacto con nosotros primero.

Si vous avez des questions qui ne sont pas traitées dans ce manuel de l'utilisateur, contactez-nous d'abord.



**Customer Service / Servicio al Cliente / Service de Clientèle**



1-800-618-6798











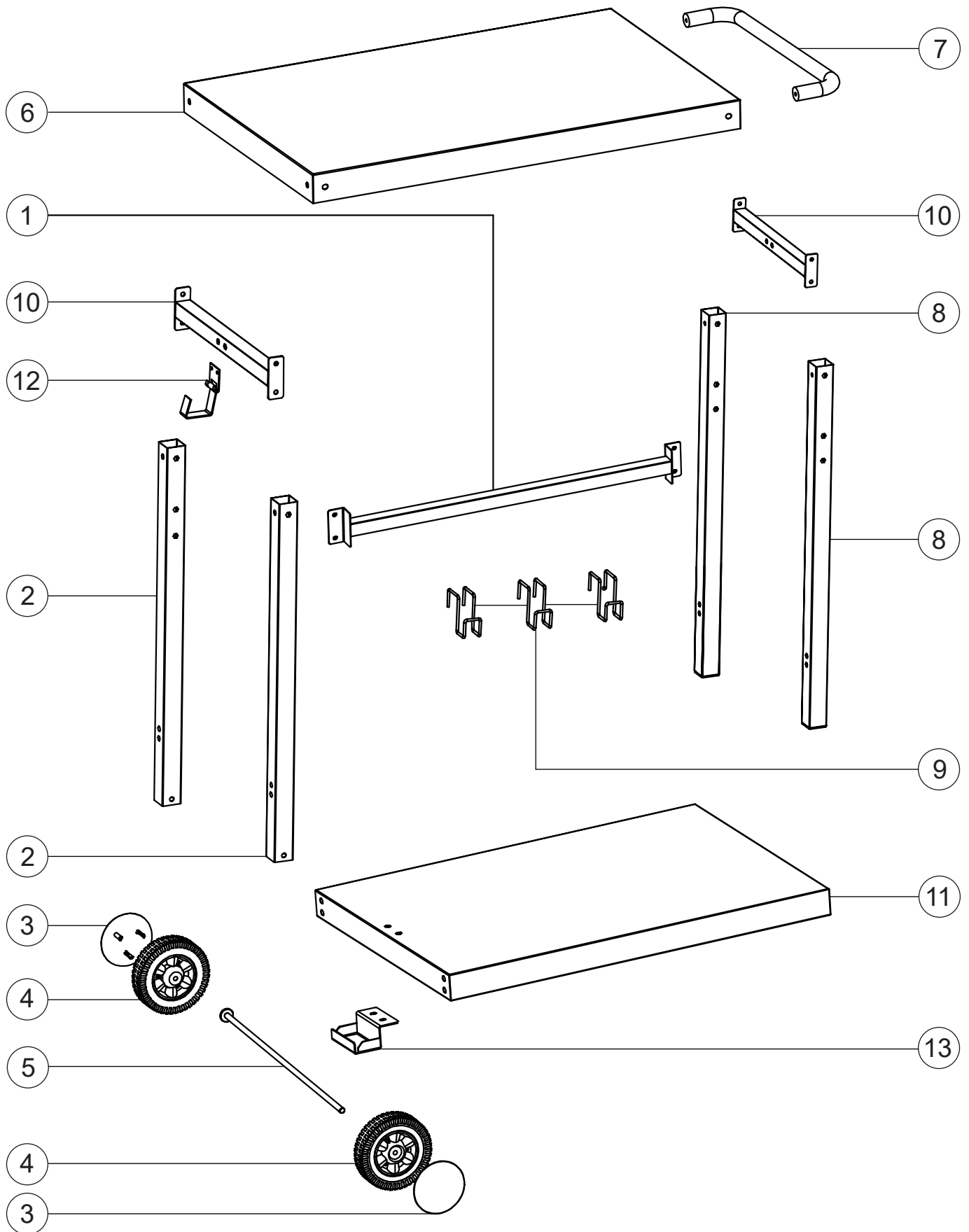

service@royalgourmetusa.com

Learn more at / Obtener más información en / Pour en savoir plus:

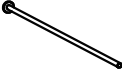

[www.royalgourmetusa.com](http://www.royalgourmetusa.com)

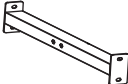
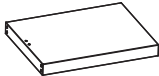









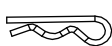

No.	#	QTY / CANT. / QTÉ	Description / Descripción / Description	Image / Imagen / l' image
1	TNJ1QLH	1	Cart front beam Viga frontal del carro Poutre avant du chariot	
2	TNJ1JGL01	2	Left leg Pata izquierda Jambe gauche	
3	05-LGL-02-SI	2	Rim cover Cubierta de la llanta Couverture de la jante	
4	05-SLL-04	2	Wheel Rueda Roue	
5	06-XZL-1-15-DY	1	Wheel axle Eje de rueda Essieu de roue	
6	TM1ZMB01-SS4	1	Table top Parte superior de la mesa Plateau de table	
7	04-GBS-2-29-456-PG	1	Handle Manija Poignée	
8	TNJ1JGR02	2	Right leg Pata derecha Jambe droite	
9	07-GGL-06-SI	3	Hook Gancho Crochet	
10	TNJ1CLH	2	Cart side beam Viga lateral del carro Poutre latérale du chariot	
11	TNJ1DCB	1	Bottom shelf Estante inferior Etagère inférieure	
12	07-QPG-01-BK	1	LP cylinder hook Gancho para bombona de gas Crochet de bouteille de gaz	
13	07-QPG-02-BK	1	LP cylinder base Base del bombona de gas Base de bouteille de gaz	

TOOLS REQUIRED / HERRAMIENTAS REQUERIDAS / OUTILS REQUIS

Phillips screwdriver Destornillador phillips Tournevis phillips	Wrench Llave Clé		
---	------------------------	--	---

No.	#	Image / Imagen / Image	No.	#	Image / Imagen / Image
A	M6x60	 x4	E	M6x15	 x12
B	M6x55	 x8	F	Washer Arandela Rondelle	 x2
C	Split pin Pasador Goupille fendue	 x1	G	Nut Tuerca Écrou	 x2
D	M6x12	 x4	H	Handle base Base de manija Base de poignée	 x2

Before beginning assembly, make sure all parts are present. If any parts are missing or damaged, do not attempt to assemble the products. Contact customer service for replacement parts via telephone or email.

- Tools needed: Phillips screwdriver and wrench (not included)
- Approximate assembly time: 15 minutes
- Note: 1. The right and left sides of the grill are designed as if you are facing the front of the grill.  
2. Model shown for illustration purpose only, specific please in kind prevail.

Antes de comenzar el montaje, asegúrese de que todas las piezas estén presentes. Si falta alguna pieza o está dañada, no intente ensamblar los productos. Póngase en contacto con el servicio de atención al cliente para obtener piezas de repuesto por teléfono o correo electrónico.

- Herramienta necesaria: Destornillador phillips y llave (no incluido)
- Tiempo aproximado de ensamblaje: 15 minutos
- Nota: 1. Los lados derecho e izquierdo de la parrilla están diseñados como si estuvieras frente a la parte delantera de la parrilla.  
2. El modelo que se muestra es sólo para fines ilustrativos, prevalecen los específicos en especie.

Avant de commencer l'assemblage, assurez-vous que toutes les pièces sont présentes. Si des pièces sont manquantes ou endommagées, n'essayez pas d'assembler les produits. Contactez le service de clientèle pour les pièces de rechange par téléphone ou par e-mail.

- Outils nécessaires: Tournevis phillips et clé (non inclus)
- Temps nécessaire pour l'assemblage: 15 minutes
- Remarque: 1. Les côtés droit et gauche du gril sont conçus comme si vous faisiez face à l'avant du gril.  
2. Le modèle est présenté à des fins d'illustration uniquement, spécifiques en nature prévalent.



**WARNING  
ADVERTENCIA  
AVERTISSEMENT**

This product can expose you to chemicals including Nickel (Metallic), which is known to the State of California to cause cancer.

For more information, go to: [www.P65Warnings.ca.gov](http://www.P65Warnings.ca.gov)

Este producto puede exponerlo a químicos, incluyendo Níquel (Metálico), que el estado de California sabe que causa cáncer.

Para más información, visite: [www.P65Warnings.ca.gov](http://www.P65Warnings.ca.gov)

Ce produit est susceptible de vous exposer à des produits chimiques, notamment le nickel (métallique), reconnu par l'État de Californie comme étant un élément cancérigène.

Pour plus d'informations, visitez: [www.P65Warnings.ca.gov](http://www.P65Warnings.ca.gov)

**1** D   $\oplus$  x4

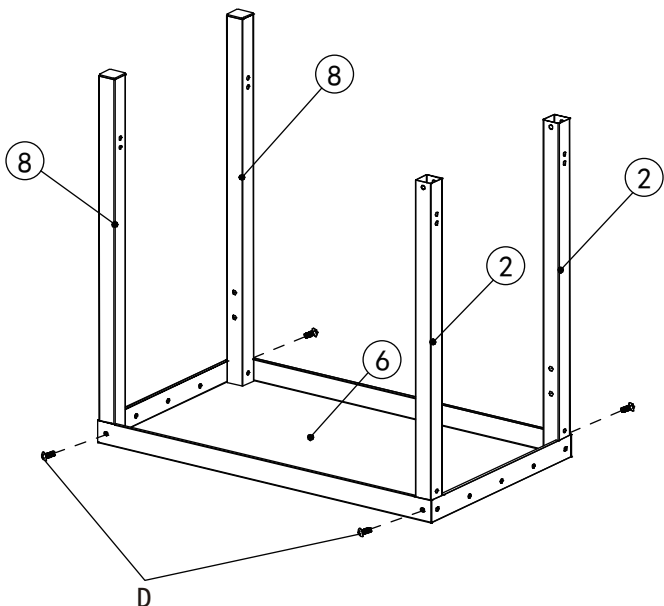

**2** A  x4 H  x2  
G  x2

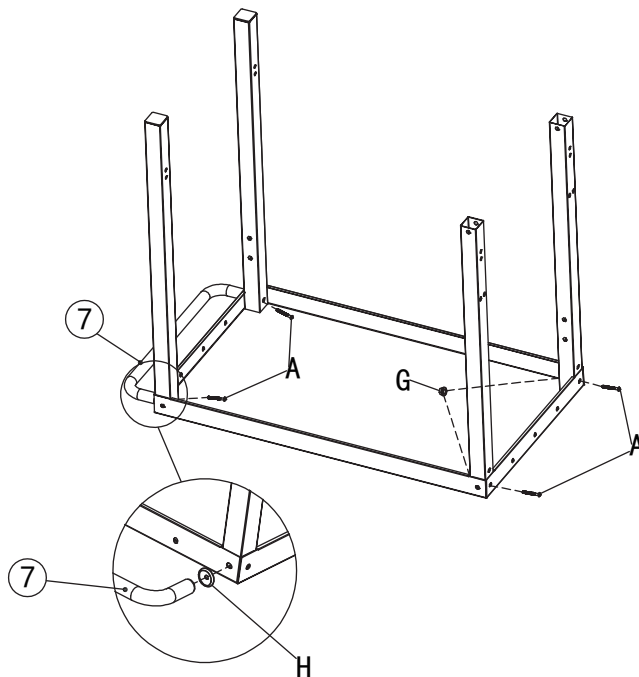



**3** E   $\oplus$  x8

**4** B  x8

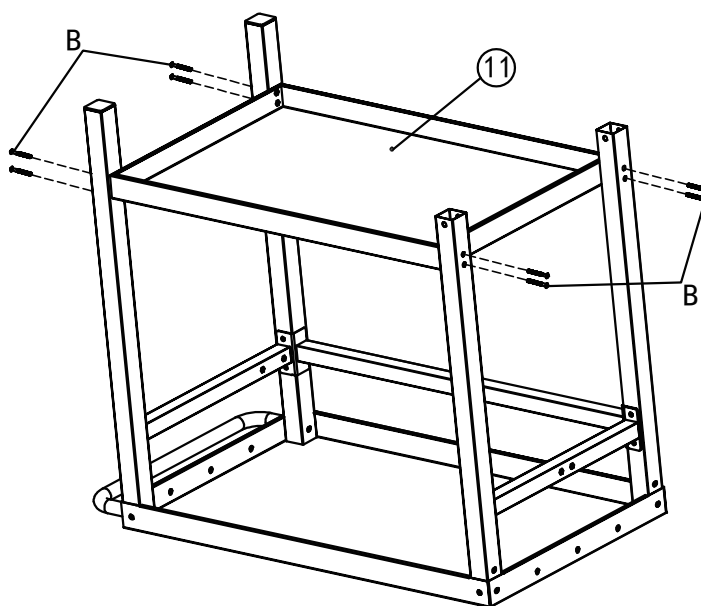
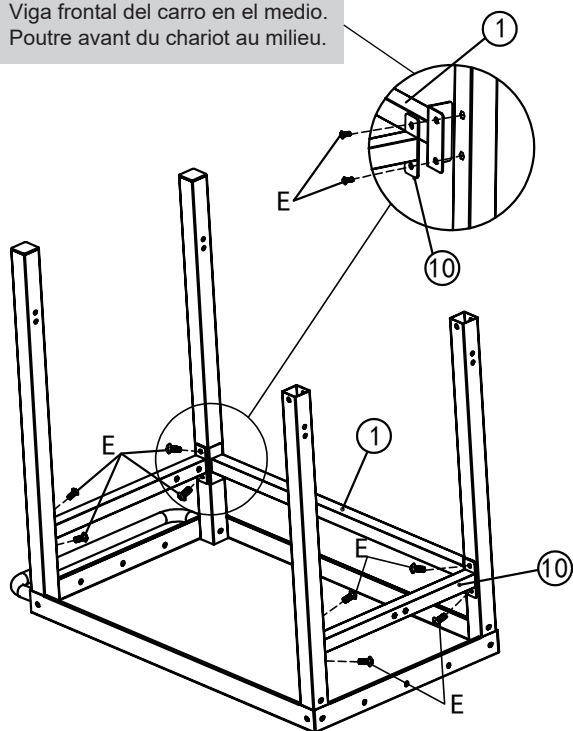
- Cart front beam in the middle.
- Viga frontal del carro en el medio.
- Poutre avant du chariot au milieu.



<b>5</b>	F		×2
	C		×1

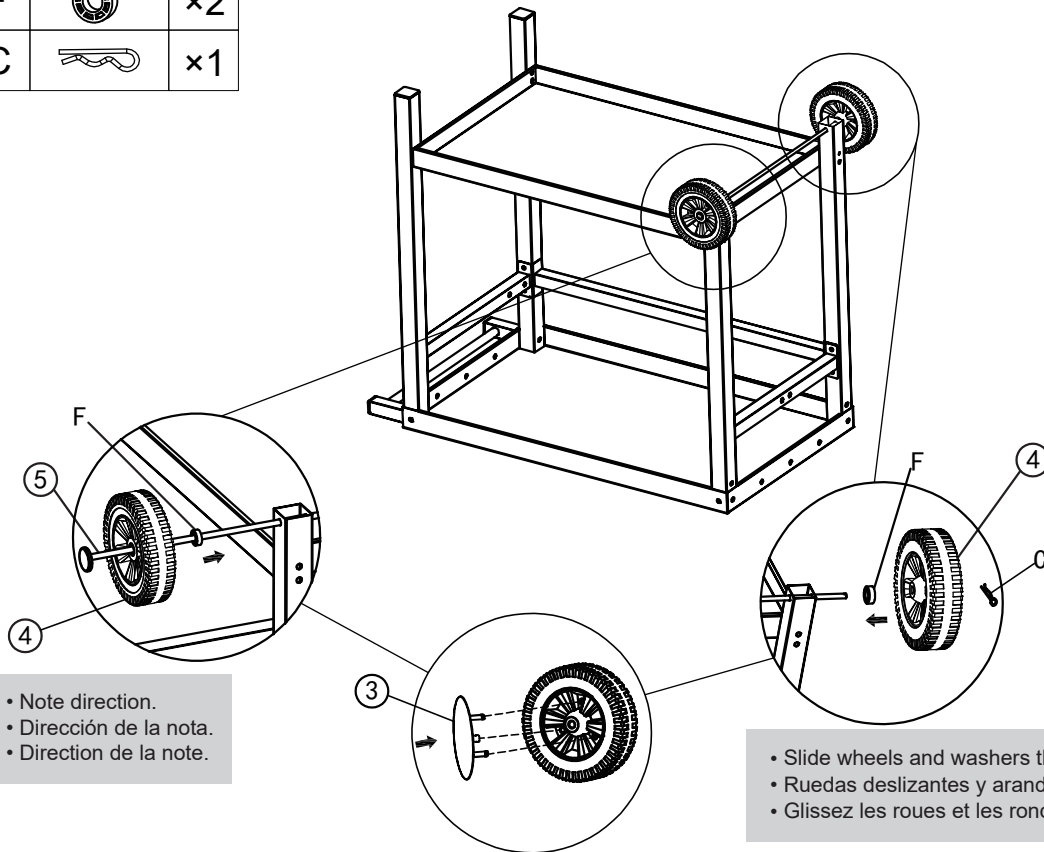

- Note direction.
- Dirección de la nota.
- Direction de la note.

- Slide wheels and washers through the axle.
- Ruedas deslizantes y arandelas a través del eje.
- Glissez les roues et les rondelles dans l'axe.

<b>6</b>	E		×4
----------	---	---	----

- The tabletop is covered with a protective film, please remove it before use.
- La superficie de la mesa está protegida con una película, retírela antes de hacer el primer uso.
- Le plateau de la table est recouvert d'un film protecteur, veuillez l'enlever avant utilisation.

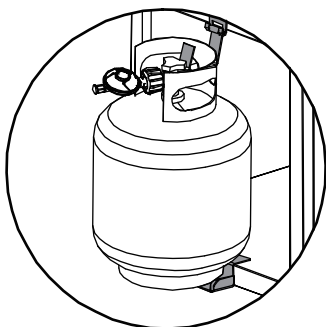

- NOTE: Secure cylinder onto hook and base.
- REMARQUE: Asegure el bombona en el gancho y la base.
- NOTA: Fixez la bouteille sur le crochet et la base.

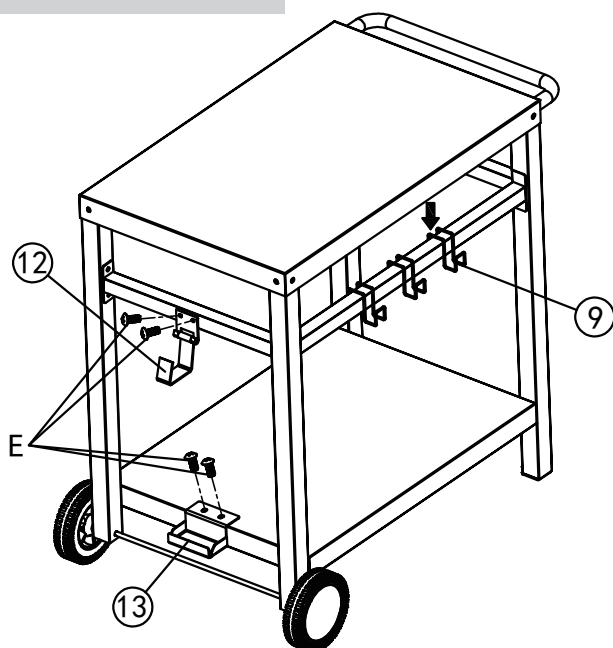

**Thank You  
For Choosing Us.**

**Any Problem!  
We Can Help!**

**Customer  
Service**

**1-800-618-6798**

**Monday to Friday (8:30 am - 5:00 pm EST)**

**[service@royalgourmetusa.com](mailto:service@royalgourmetusa.com)**